

serverLIFT

www.serverlift.com

Operator's Manual

ServerLIFT™
SL-500FX

**Electric Front Loading
Data Center Lift**

Serial #: _____

As a certified ISO:9001 and ISO:14001 manufacturer, ServerLIFT has made a commitment to our customers, suppliers, and community, to continuously improve and to deliver products and services that meet or exceed the highest standards for quality and minimizing environmental impact.



NOTICE

**ONLY ORIGINAL SERVERLIFT
REPLACEMENT PARTS SHALL BE
USED FOR ANY REPAIR.**

Introduction	4
Included with the SL-500FX device	4
Legend	5
Set Up	7
Before you begin	7
Pre-operation Inspection	7
Function Tests	7
Instructions	11
Before operating the ServerLIFT unit	11
Operating Steps	11
Stabilizer Brake Operation	12
Applying Load To The Platform	13
Front Caster Swivel Lock Operation	13
Safety Directions	14
Attachments	15
FE-3X™ Shelf Extender	15
GT-1000X™ Glide Table	17
RL-500™ Platform Riser	19
RS-500X™ Rail Lift	20
Maintenance	24
Schedule of Maintenance	24
Battery Charging	25
Panel Access Door	26
Testing Battery Charge	26
Battery Replacement	27
Stabilizer Brake Boot Replacement	29
Pulley and Cable Inspection	30
Specifications	31
Features	31
Dimensions and Capacity	33
Troubleshooting	34
Warranty	38
CE Declaration	40
FCC Declaration	42

ServerLIFT Corporation

17453 N 25th Ave | Phoenix, AZ USA 85023
(602) 254-1557 | Fax: (602) 254-1975



Service & Support:
support@serverlift.com

Shipping/Receiving:
shipping@serverlift.com

Sales:
sales@serverlift.com

© ServerLIFT Corporation. All Rights Reserved.
Information in this document subject to change without notice.

05-2020 P/N: SL-5F r.B03

⚠ CAUTION:

Read and completely understand the contents of this Operator's Manual before operating the ServerLIFT device. Failure to read, understand, and follow instructions in this manual may result in property damage and/or personal injury. If you do not understand any part of this manual or if you have any questions please contact ServerLIFT Service & Support.

IMPORTANT: Keep these instructions with the ServerLIFT device.

- Do not stand or ride on any part of the ServerLIFT device.
- Never lift or move the ServerLIFT device with a pallet truck, jack, or forklift. Use the pallet, ramp, and packaging originally received with the unit for transporting it.
- Keep hands, fingers and clothing clear of platform and mast when equipment is in motion.
- To maximize battery life, keep machine charging when not in use. Always disconnect the Power Cord from charging source before use or servicing.

Never operate the ServerLIFT device while charging

Included with the SL-500FX device

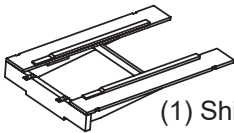

(1) Shipping Ramp

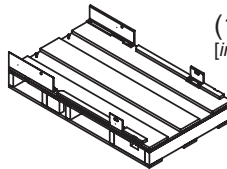

(1) Shipping Pallet
[includes retaining hardware]

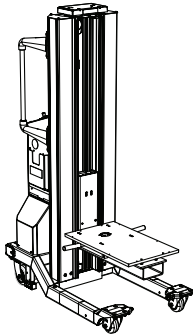

(1) SL-500FX unit



(2) Power Switch Key
[keep one key as a spare in a secure location away from ServerLIFT unit]



- (1) Operator's Manual
- (1) Canvas Bag for Tie Down Straps
- (2) Adjustable Tie Down Strap with hooks
- (1) Ratchet with (2) 17 mm and 15 mm deep sockets

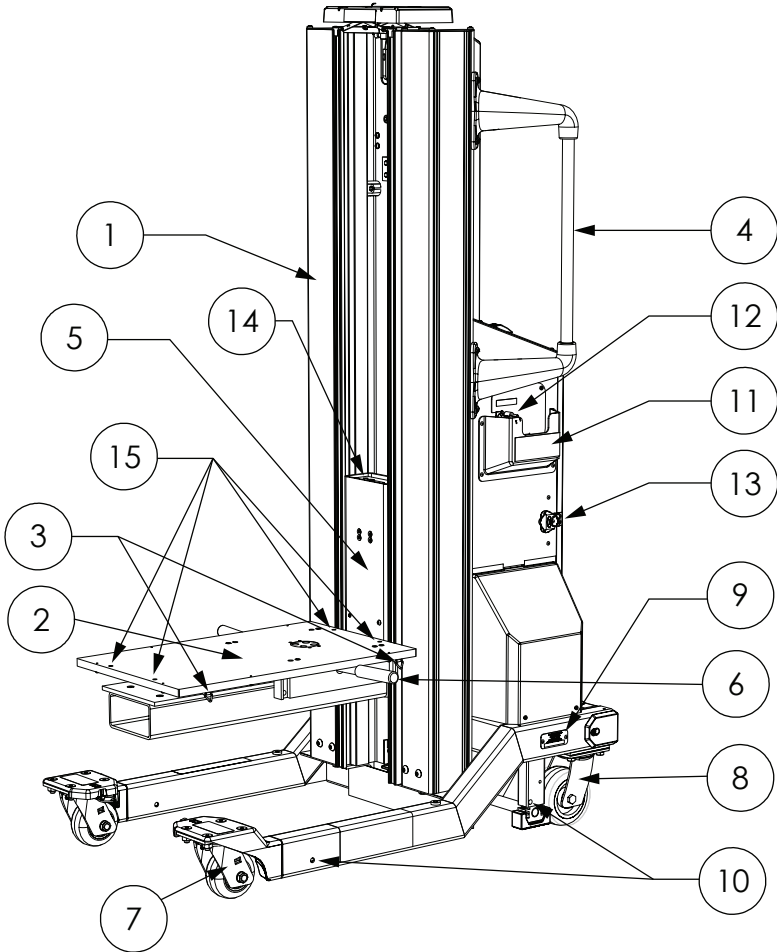

- | | |
|---|-----------------------------------|
| 1. Vertical Mast | 8. Casters - Free Swivel |
| 2. Equipment Platform and Easy-Tilt Glide Shelf | 9. Serial Number Plate |
| 3. Strap Hooks | 10. Pallet Bolt Holes |
| 4. Handle Bars | 11. Power Cord Sleeve |
| 5. Platform Mast | 12. Power Cord |
| 6. Easy-Glide Shelf Handle | 13. Panel Access Door Latch |
| 7. Casters - Swivel/Lock | 14. Platform SmartTILT Adjustment |
| | 15. Attachment Connector Holes |

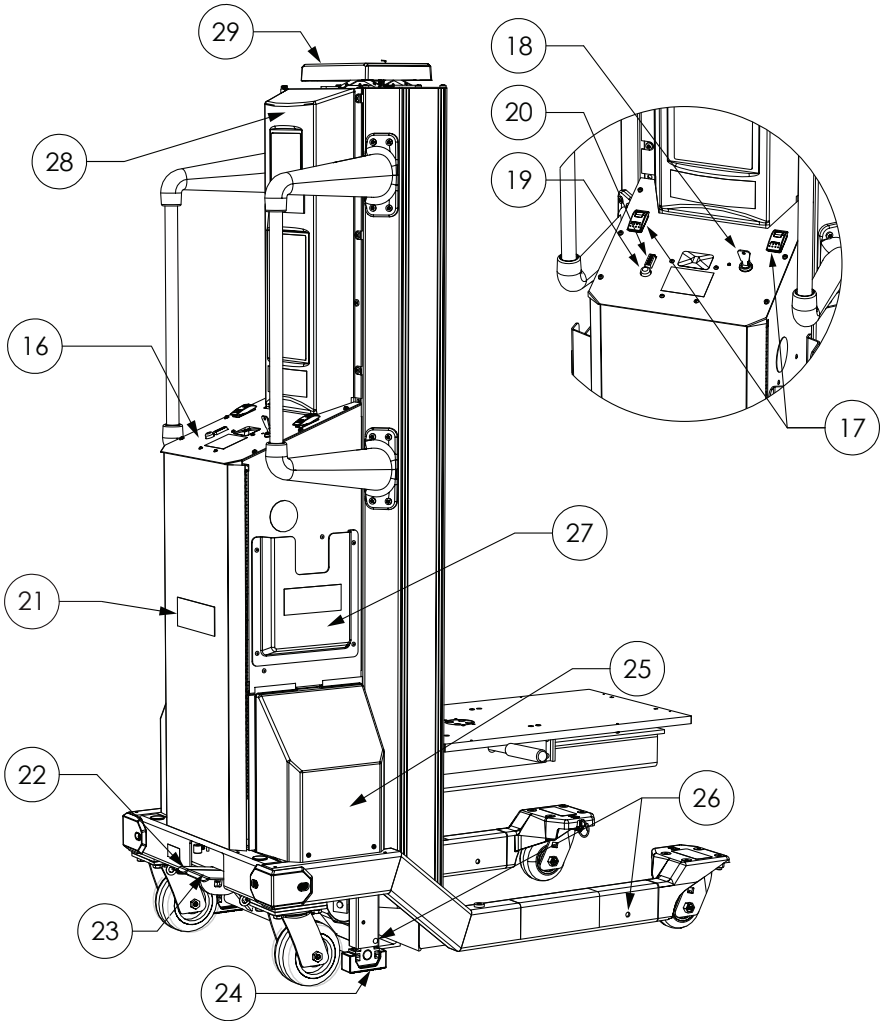

- | | |
|------------------------------------|------------------------------|
| 16. Main Control Panel | 23. Stabilizer Brake Pedal |
| 17. Up/Down Control Switches | 24. Stabilizer Brake Pad |
| 18. Keylock Power Switch | 25. Winch Cover |
| 19. Battery Charge Test Button | 26. Pallet Bolt Holes |
| 20. Battery Charge Level Indicator | 27. Operator's Manual Sleeve |
| 21. Panel Access Door | 28. Upper Panel Cover |
| 22. Stabilizer Brake Release Pedal | 29. TouchSTOP™ Sensor |

Before you begin

1. Read and understand the contents of this manual carefully.
2. Locate the serial number plate. Record unit serial number on front page of Operator's Manual for future reference.
3. Perform **Pre-operation Inspection**.
4. Perform **Function Tests**.

Pre-operation Inspection

Check the ServerLIFT device and included attachments (if applicable) for signs of damage. Fully document any damage with photos, location, and description. Promptly contact ServerLIFT Service & Support if any damage is present.

SAVE PALLET, RAMP, HARDWARE AND PACKING CARTON!

They are needed for moving the ServerLIFT unit to other locations.

Function Tests

Function Tests are designed to discover malfunctions before machine is used. Tests should be performed before normal operation. Before testing, select an area that is solid, level and free of obstructions.

⚠ **Note:** *After testing, if malfunctions are discovered, the machine must be locked in OFF status and removed from service. Repairs to the machine may only be made by or under the directions of a service technician qualified by ServerLIFT.*

Battery Charge

To test battery charge, press Battery Charge Test Button on Main Control Panel, activating Battery Charge Level Indicator.

There are three zones on Charge Level Indicator: DISCHARGED (red), LOW (amber), and FULL (green). If charge level is FULL, the Battery is considered fully charged.

If Battery is not fully charged, recharge it before continuing Set Up (see "Battery Charging" on page 25).

➔ **Note: Charge the Battery whenever the ServerLIFT device is not in active use to maximize battery life.**

⚠ CAUTION

Never plug into a wall outlet or power source that is not approved for your ServerLIFT model. See "Battery Charging" on page 25 for approved power source specifications.

CHARGING BATTERY WITH UNAPPROVED POWER SOURCE OR OPERATING UNIT WHILE CHARGING WILL VOID WARRANTY AND RESULT IN PERMANENT CHARGING SYSTEM FAILURE.

Stabilizer Brake Function Test

See "Stabilizer Brake Operation" on page 12 for additional details.

1. Press down red Stabilizer Brake Pedal so it locks in place. The Stabilizer Brake should remain in DOWN position.

➔ **Note: If operating correctly, engaging the Brake will very slightly lift the back of the ServerLIFT machine up off the ground. Applying additional force may be required to engage the Stabilizer Brake at the point where it lifts the unit and locks in place. If too much force is needed, or the Stabilizer Brake does not lift the back wheels up, contact ServerLIFT Service and Support.**

2. Attempt to move the ServerLIFT machine. It should be locked in place and not be able to move. If it rolls at all, or Stabilizer Brake does not lock in DOWN position, contact ServerLIFT Service and Support.

3. To release, press green release pedal and allow pedals to return to UP positions. If operating correctly, proceed to next Function Test.

Winch Motor Function Test

1. Engage the Stabilizer Brake.
2. Turn unit power on by inserting key and turning clockwise to **ON (-)** position.
3. Press Up/Down Control Switch to move Platform **UP**. Test full range of motion up and down. Platform will automatically stop in fully extended and fully retracted positions. If Platform does not travel full range of motion consistently, contact ServerLIFT Service and Support.

🔊 **Note: Clicking or ratcheting noises are normal when raising/lowering Platform.**

⚠️ WARNING

Platform Mast extends higher than Platform. When raising Platform, be aware of ceiling height, cable trays, sprinklers, lights, and other overhead obstructions.

4. Repeat step 2 with second Up/Down Control Switch. As Platform Mast extends above the Vertical Mast, press TouchSTOP™ Sensor above Platform Mast while continuing to raise Platform. Platform should stop. Release TouchSTOP Sensor. Platform should only resume motion when Up/Down Control Switch is released and pressed again. If TouchSTOP Sensor does not stop Platform when depressed or operate as described herein, contact ServerLIFT Service and Support.

🔊 **Note: TouchSTOP Sensor will stop Platform motion, even before Platform Mast extends above Vertical Mast.**

SmartTILT Platform™/Easy-Glide Shelf™ Function Test

1. Engage Stabilizer Brake.
2. Turn unit power on by inserting key and turning clockwise to **ON (-)** position.
3. Raise Platform above casters to a comfortable working height.

Set Up

4. Push down on handle to unlock and allow movement of Easy-Glide Shelf. Shelf will shift forward up to 11.48 inches. There are multiple incremental adjustment locations.

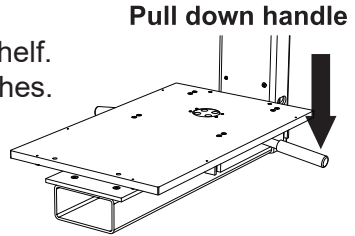

5. Test full movement of Easy-Glide Shelf in both directions. If shelf does not travel entire range of motion consistently or does not lock at incremental adjustment locations, contact ServerLIFT Service and Support.

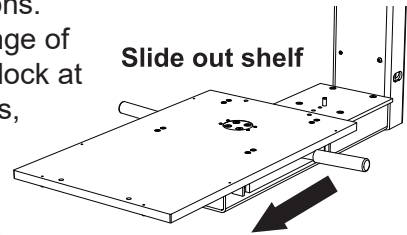

6. Return Shelf to neutral (center) position.

7. Test operation and range of motion of the SmartTILT Platform by using the included ratchet and 15 mm deep socket to slowly adjust the Platform angle UP and DOWN. Stop as soon as adjustment resistance is felt. Optionally use a level to measure the angle which should be approximately 0.5 degrees DOWN and 1.5 degrees (or more) UP.

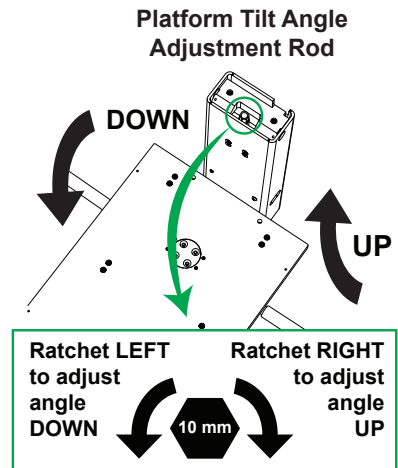

⚠ WARNING

NEVER over-adjust the SmartTILT Platform angle. Adjust angle slowly and STOP as soon as resistance to the angle adjustment can be felt.

Before operating the ServerLIFT unit

1. Read and understand the operating steps and functions well.
2. Remove any objects or obstructions around or under the ServerLIFT unit, or in travel area of Platform.
3. Make sure Battery is charged.
4. Make sure Stabilizer Brake engages and locks in place. Both Stabilizer Brake Pads must be installed and engage floor correctly (see **Stabilizer Brake Operation** on pg. 12).

Operating Steps

1. Position the ServerLIFT unit
2. Engage Stabilizer Brake
3. Power the ServerLIFT unit **ON** (-)
4. Raise Platform to desired loading height
5. Load server or equipment onto Platform
6. Secure server using Adjustable Tie Down Straps*
7. Lower Platform to lowest position
8. Power the ServerLIFT unit **OFF** (O)
9. Release Stabilizer Brake
10. Move the ServerLIFT unit to destination
11. Engage Stabilizer Brake
12. Power the ServerLIFT unit **ON** (-)
13. Raise platform to desired unloading height
14. Adjust Platform angle as desired for leveling the server using SmartTILT adjustment feature
15. Load server from Platform and Easy-Glide Shelf™ into rack
16. Lower Platform to lowest position
17. Power the ServerLIFT unit **OFF** (O)
18. Release Stabilizer Brake
19. Charge ServerLIFT unit when not in use



⚠ DANGER
NEVER raise or lower platform with shelf out of neutral (center) position.

* especially critical when moving the ServerLIFT unit across uneven or not level ground

Stabilizer Brake Operation

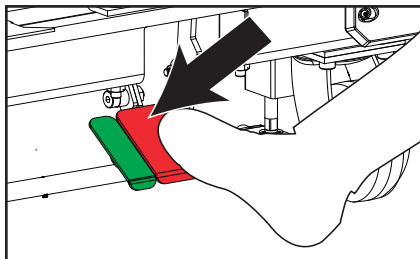

To engage Stabilizer Brake, depress red pedal until it locks in **DOWN** position. The back of the ServerLIFT unit should slightly lift up off the ground. The ServerLIFT unit should not move. If ServerLIFT unit moves, the Stabilizer Brake is not functioning properly. Contact ServerLIFT Service and Support.

ⓘ **Note:** *Without equipment on the platform, average force is all that is needed to fully depress Stabilizer Brake. The force required will increase as equipment/weight is added to the platform.*

Once Stabilizer Brake is locked in **DOWN** position, ServerLIFT unit is stabilized, parked and ready for use. Follow **Operating Steps** on page 11 (steps 3-8 or 12-16).

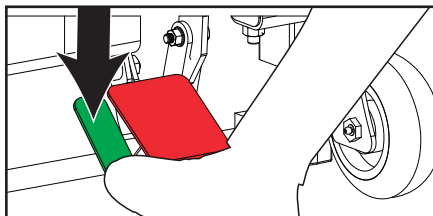
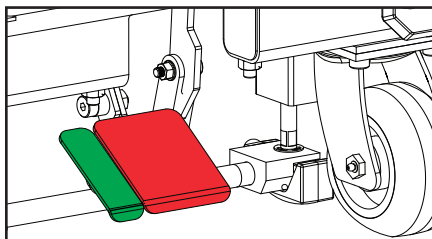

Press on green release pedal until unlocked and slowly pull foot back allowing both pedals to fully retract.

⚠ WARNING

- Always engage Stabilizer Brake before raising, lowering, or sliding Easy-Glide Shelf™
- Engage Stabilizer Brake whenever ServerLIFT unit is not in motion
- ServerLIFT unit will/should not move with Stabilizer Brake engaged

Applying Load To The Platform

⚠ WARNING

NEVER place more than the maximum load on edge of Platform Shelf. The maximum rated load at the edge is reduced when the Platform Shelf is extended. NEVER raise or lower platform with shelf out of neutral (center) position.

⚠ WARNING

SL-500FX[®]
MAX. LOAD



500 lbs
(227 kg)

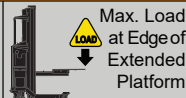

300 lbs
(136 kg)

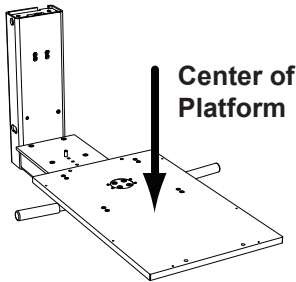

Edge of Platform

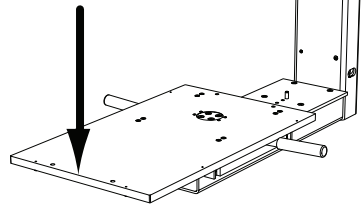

Front Caster Swivel Lock Operation

UNLOCKED

To unlock Front Caster, pull out ring and turn 90 degrees in either direction. Allow ring to align in horizontally (perpendicular) to groove as shown.

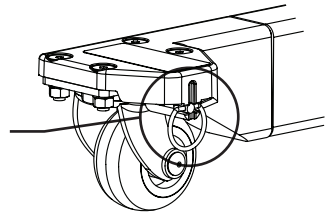

LOCKED

To lock Front Caster, pull ring out and turn 90 degrees in either direction. Allow ring to align in vertical groove as shown. Ensure caster is in line with base frame arm and pointing backward. An audible click indicates the lock is engaged.

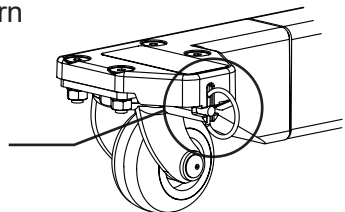

Safety Directions

Fall Hazards

- Do not stand on any part of lift.
- Do not climb on mast.
- Do not use as a personnel lifting platform or step.

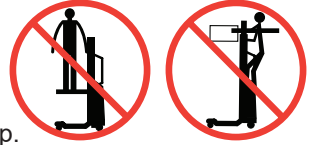

Tip-over Hazards

- Do not lift load unless stabilizer is fully engaged.
- Do not move machine while platform is raised, except for minor positioning.
- Only raise load if properly centered on platform.
- Do not operate while under the influence of drugs or alcohol.
- Do not stand under overhanging load.
- Do not exceed rated load capacity.
- Do not stack loads.
- Do not support ladder against ServerLIFT unit.
- Do not use on uneven or graded surface



Collision Hazards

- Only lower load in areas clear of personnel and obstructions.
- Platform Mast extends higher than Platform. Be aware of ceiling height, cable trays, sprinklers, lights, and other overhead objects.



Damaged Machine Hazard

- Do not operate a damaged or malfunctioning ServerLIFT machine.



Improper Use Hazard

- Do not leave machine unattended with an elevated load.
- Do not raise or lower platform with shelf out of neutral (center) position OR with handle not retracted.



Pinch Point Hazard

- Keep hands clear of moving parts and open sections during operation.
- Hands should only be on handle bars and/or on designated locations needed for operation.



FE-3X™ Shelf Extender

The ServerLIFT FE-3X Shelf Extender makes face-mounted and fixed-rail installations easy by providing rigid support for the server deep into any rack.

For use with the ServerLIFT SL-500FX Front Loading lift, the FE-3X Shelf Extender nearly doubles the forward reach of the SL-500FX platform. It is perfect for facilities with wide aisles and for manufacturers loading into cabinets mounted on pallets.

⚠ WARNING

- Do not stand or ride on any part of Shelf Extender.
- Do not exceed the maximum load of 500 lbs (227 kg).
- Do not use together with LE-500X or LE-1000X Lift Extensions or PL-500X Platform Extension.
- Do not operate with a load that has a center of mass placed forward (away from the ServerLIFT unit) of indicated Shelf Extender Load Center.
- No corner load.

SECURE SHELF EXTENDER TO SERVERLIFT SHELF IN ALL FOUR LOCATIONS (WITH PROVIDED HARDWARE ONLY) PRIOR TO USE

Included with FE-3X Shelf Extender

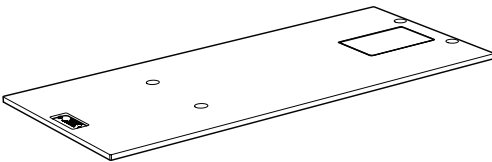

(1) FE-3X attachment unit

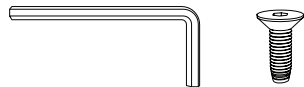

(1) Allen Wrench

(4) Screws

Attaching FE-3X Shelf Extender to the ServerLIFT unit

1. Engage ServerLIFT Stabilizer Brake.
2. Place FE-3X Shelf Extender onto ServerLIFT unit platform. Line up holes on shelf extender with threaded holes on ServerLIFT unit platform.
3. Secure Shelf Extender to platform with Thumbscrews and in all four locations as shown.

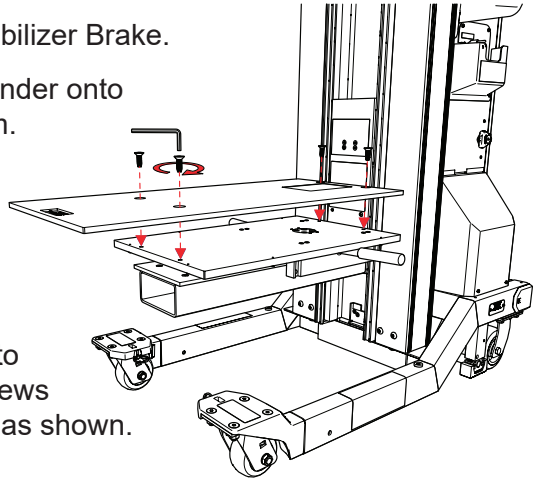

⚠ WARNING

Shelf Extender must be secured in all four locations

➡ **Note:** *Shelf Extender should be removed and set aside when not in use.*

➡ **Note:** *Proper setup, installation, and use of this product is the sole responsibility of the installer.*

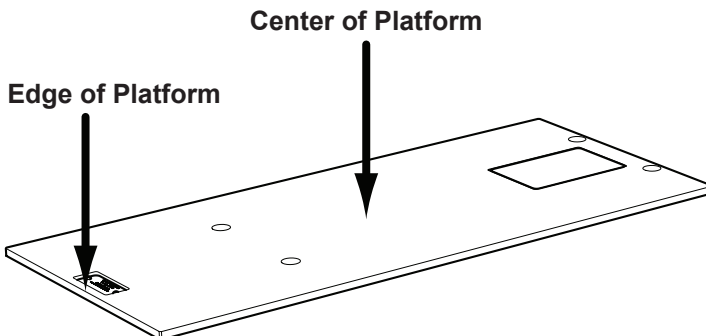

GT-1000X™ Glide Table

The ServerLIFT GT-1000X Glide Table allows servers to glide back and forth for frictionless install or removals on either side of an aisle. Allows for right or left hand operation on SL-500FX Front Loading lift. Can be attached to and used in conjunction with the RS-500 Platform Riser.

⚠ WARNING

- Do not stand or ride on any part of Glide Table.
- Do not exceed the maximum load of 500 lbs (227 kg).
- Do not use together with LE-500X or LE-1000X Lift Extensions or PL-500X Platform Extension.
- No corner load.

**SECURE GLIDE TABLE TO SERVERLIFT SHELF
IN ALL FOUR LOCATIONS (WITH PROVIDED
HARDWARE ONLY) PRIOR TO USE**

Included with GT-1000X Glide Table

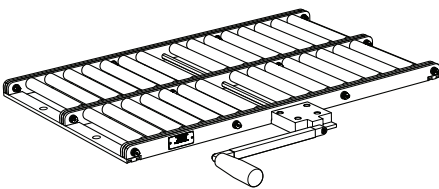

(1) GT-1000X Attachment Unit

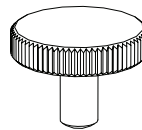

(4) Thumb Screws

Attaching GT-1000X Glide Table to the ServerLIFT unit

1. Engage ServerLIFT Stabilizer Brake.
2. Place GT-1000X Glide Table onto ServerLIFT unit platform. Line up holes on Glide Table with threaded holes on ServerLIFT unit platform.
3. Secure Glide Table to platform with Thumbscrews and in all four locations as shown.

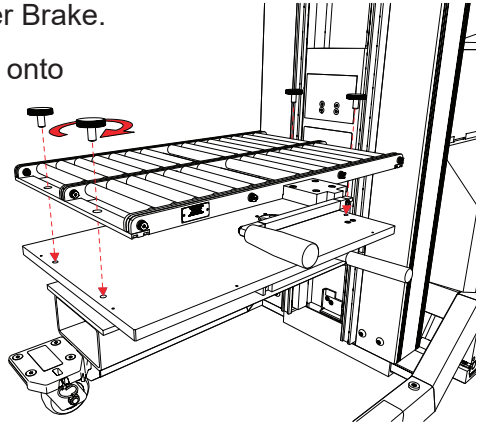

Note: *Glide Table can be installed with the table lock handle on either side of the ServerLIFT unit.*

GT-1000X Glide Table Lock Operation

UNLOCKED

To unlock Glide Table swing handle up and to the right until it sits firmly in place.

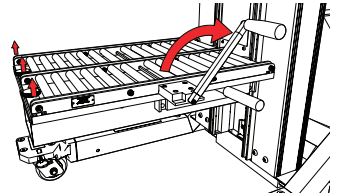

LOCKED

To lock Glide Table swing handle to the left until it sits firmly in place.

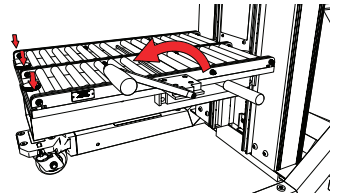

Note: *Glide Table should be removed and set aside when not in use. Four holes on Glide Table are provided for convenient storage of Thumbscrews when not in use.*

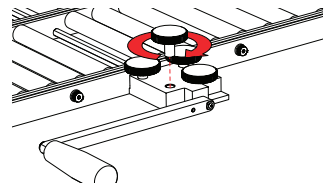

RL-500™ Platform Riser

The ServerLIFT RL-500™ Platform Riser attachment enables users to install servers at the top of any rack in areas where equipment positioning is a challenge. These situations include:

- Low ceilings clearance or obstructions
- Cold and hot aisle containment rooms
- Ten foot (3 meter) tall racks
- Drop in rails

The ServerLIFT RL-500 Platform Riser features a lightweight yet rugged design, and is compatible with all current and past models of ServerLIFTS.

Included with the RL-500 Platform Riser

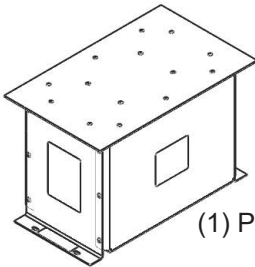

(1) Platform Riser

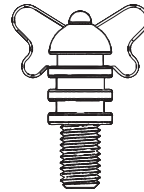

(4) Thumbscrew

⚠ WARNING

- Do not stand or ride on any part of Platform Riser.
- Do not exceed the maximum load of 500 lbs (227 kg).
- Do not use together with LE-500X or LE-1000X Lift Extensions or PL-500X Platform Extension.
- No corner load.

SECURE PLATFORM RISER TO SERVERLIFT SHELF IN ALL FOUR LOCATIONS (WITH PROVIDED HARDWARE ONLY) PRIOR TO USE

Attaching Platform Riser to the ServerLIFT Platform

1. Engage ServerLIFT Stabilizer Brake.
2. Place Platform Riser onto ServerLIFT Easy-Glide Shelf. Line up slotted holes in bottom flanges of Platform Riser with threaded holes on ServerLIFT Easy-Glide Shelf.
3. Secure Platform Riser to Shelf with Thumbscrews in all four locations as shown.

⚠ WARNING

Platform Riser must be secured in all four locations

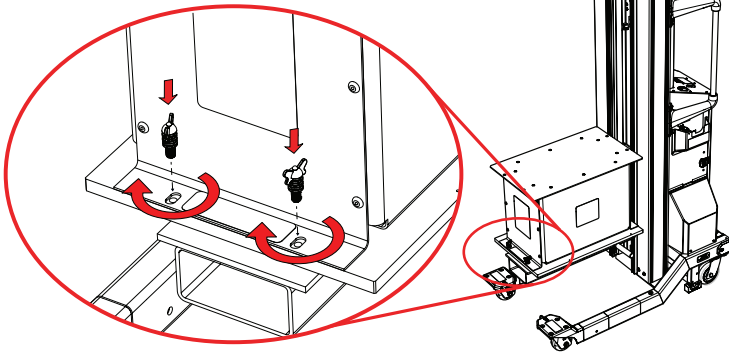

➡ **Note:** Platform Riser should be removed and set aside when not in use. Four holes on Platform Riser top plate are provided for convenient storage of Thumbscrews and Washers when not in use.

RS-500X™ Rail Lift

The ServerLIFT RS-500X Rail Lift attachment enables users to position and support servers at an angle for installation or removal from slotted or drop-in rails.

The ServerLIFT RS-500X Rail Lift features a low profile yet rugged design, and is compatible with all current and past models of

ServerLIFTs. Its convenient, multi-hinged crank handle can be used to adjust the angle of the equipment surface from flat level up to 5° of angled position.

The ServerLIFT RS-500X Rail Lift can be secured to the ServerLIFT Platform Shelf in one of two positions, allowing the Operator the choice of using it from the **left or right side of the ServerLIFT SL-500FX device**. The RS-500X Rail Lift can also be used in conjunction with the RL-500 Platform Riser.

Included with the RS-500X Rail Lift

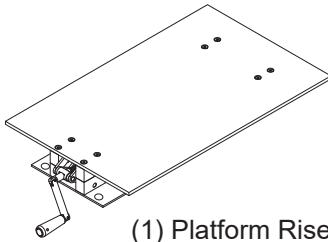

(1) Platform Riser



(4) Thumbscrew

⚠ WARNING

- Do not stand or ride on any part of Rail Lift.
- Do not exceed the maximum load of 500 lbs (227 kg).
- Do not use together with LE-500X or LE-1000X Lift Extensions or the PL-500X Platform Extension
- No corner load.

SECURE RAIL LIFT TO SERVERLIFT SHELF IN ALL FOUR LOCATIONS PRIOR TO USE (USING PROVIDED HARDWARE ONLY)

Attaching to ServerLIFT Platform or RL-500X Riser

1. Engage ServerLIFT Stabilizer Brake.
2. If installing onto the Platform Riser, ensure that the RL-500 Platform Riser is attached and secured to the ServerLIFT Easy-Glide Shelf per the directions "Attaching Platform Riser to the ServerLIFT Platform" on page 20.

1. Place the RS-500X Rail Lift onto ServerLIFT Easy-Glide Shelf or RL-500 Platform Riser. Line up the four holes in the base plate of Rail Lift with threaded holes on ServerLIFT Easy-Glide Shelf or RL-500 Platform Riser.
2. Secure the RS-500X Rail Lift to Shelf with Thumbscrews in all four locations as shown below.

⚠ WARNING
Rail Lift MUST
be secured in all
four locations

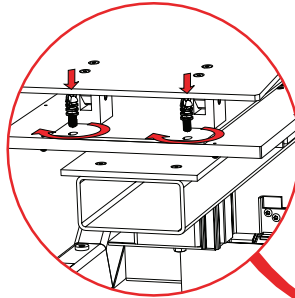

Installed on
Platform Shelf

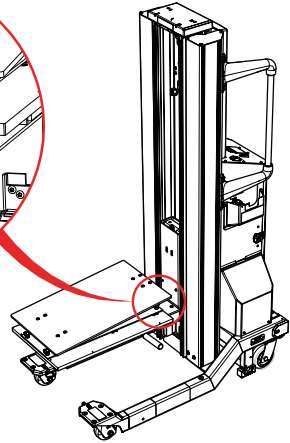

Installed on
RL-500 Riser

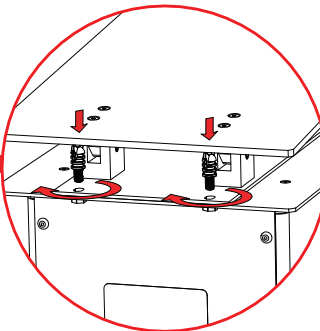
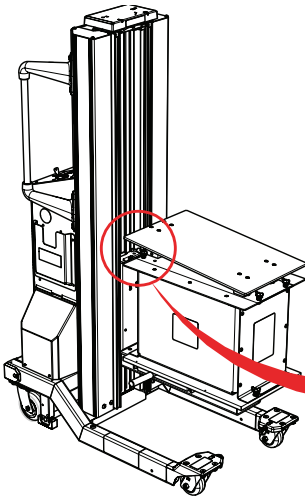

Using the Rail Lift

1. Ensure that the RS-500X Rail Lift is attached to the Easy-Glide Shelf or the RL-500 Platform Riser as needed per the above directions.

2. Follow "Operating Steps" on page 11.
3. For installs, raise platform to a height where the equipment nailheads are just above the installation rails.
4. Shift Easy-Glide Shelf towards the rack and rails. Extend the rails out to line up with nailheads.
5. Angle Equipment using Rail Lift by rotating the handle so the nailhead closest to the rack is positioned just above the slot.
6. Lower Platform so the first nailhead lowers into its slot.
7. Guide the other nailhead(s) into their corresponding rail slot(s) using the RS-500X Rail Lift by rotating the handle to reduce the equipment angle.

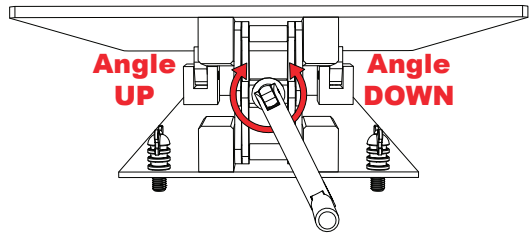

8. Once all nailheads are lined up in their respective rail slots, lower the Platform so equipment is fully supported by the rails. Reverse these steps for un-racking server equipment.

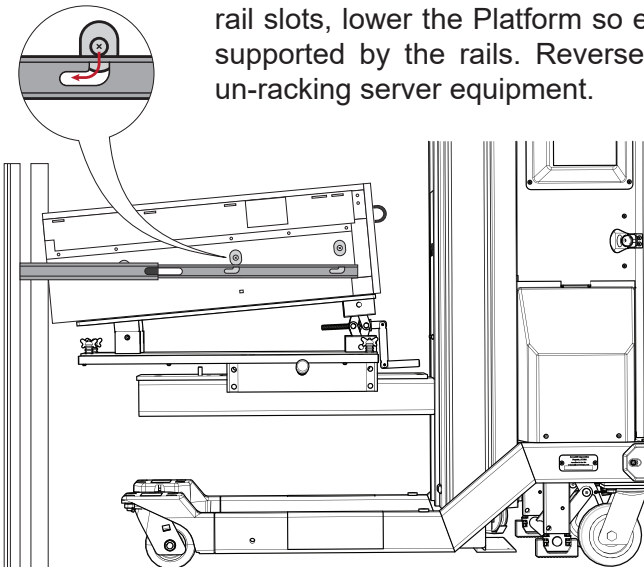

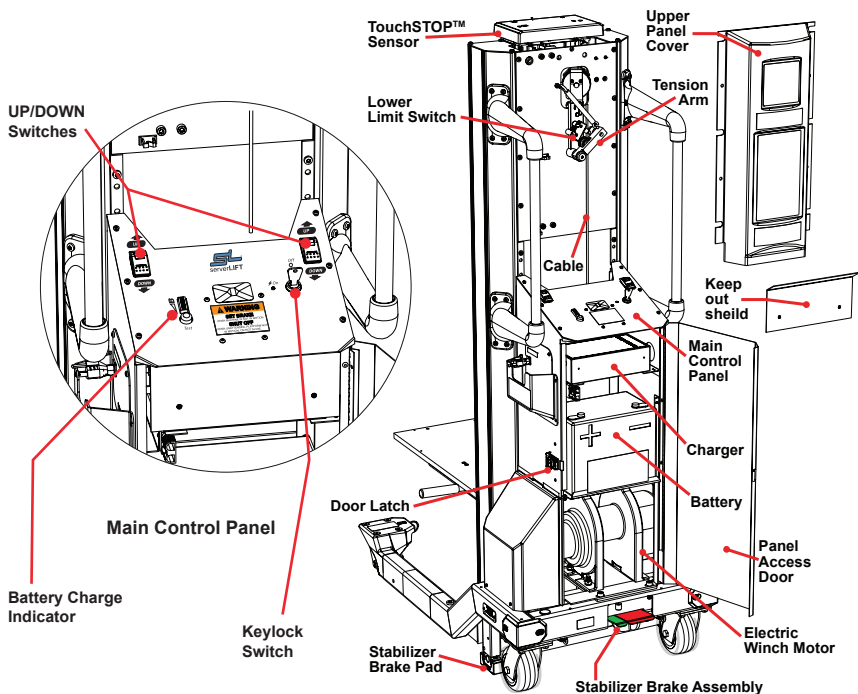

Schedule of Maintenance

Activity	Required Frequency
Charge Battery	Daily (whenever unit not in use)
Replace Battery	As needed
Replace Stabilizer Brake Pads	As needed
Inspect Winch Cable	Every 12 months
Inspect Pulleys	Every 12 months
Flush and Change Winch Oil*	Every 12 months (suggested)*

* Oil replacement kits and directions are available from ServerLIFT Service & Support.

Note: Units covered under optional Extended Service and Warranty contracts have all above maintenance checks (except for battery replacement) performed as part of ServerLIFT's annual service visit.

Battery Charging



The SL-500FX® data center lift is equipped with a rugged, compact battery charger that recharges the onboard 12V 80Ah VRLA battery.

The charger is automatic and simply needs to be plugged in to a suitable power supply or standard outlet, up to 240V.

The charger comes with a male, C14 receptacle, and a power cord with female C13 on one end and a 3-pin, Type B on the other end. However, any compatible female C13 power cord (with the local plug termination type you prefer) can be attached to it for plugging into your power supply or outlet.

The configuration and electrical requirements of are as follows:

	SL-500FX® SL-500FXi®
Indicated Voltage	100-240V
Max. Frequency Input	50/60 Hz
Max. Current Input	3.5A
Cord termination	Any 6ft grounded AC
Cord-end	Male C14 inlet receptacle
Plug Style	Any (3-pin, Type-B provided)

NOTICE	 DANGER
KEEP CHARGING WHEN NOT IN USE TO MAXIMIZE BATTERY LIFE	 UNPLUG BEFORE OPERATING OR SERVICING

WARNING:

- **NEVER** plug into an outlet with service outside model Voltage Input Range. Charger failure will result.
- **NEVER** operate a charger with a damaged cord or plug.
- When using an extension cord, a quality grounded cord of at least 16 AWG wire size (cords up to 50'/15 m) is required.

Panel Access Door

Opening

1. Flip Latch Tab up towards door.
2. Rotate counterclockwise until latch separates from Door Keeper Plate.
3. Flip entire latch assembly up away from door.
4. Open Panel Access Door.

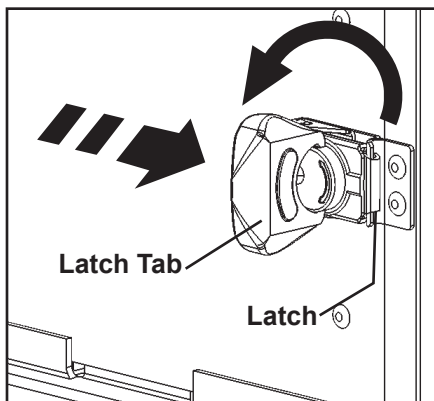

Closing

1. Close Panel Access Door.
2. Flip entire latch assembly down towards door until it covers Door Keeper Plate.
3. Rotate Latch Tab clockwise until Latch engages Door Keeper Plate.
4. Flip Latch Tab down.

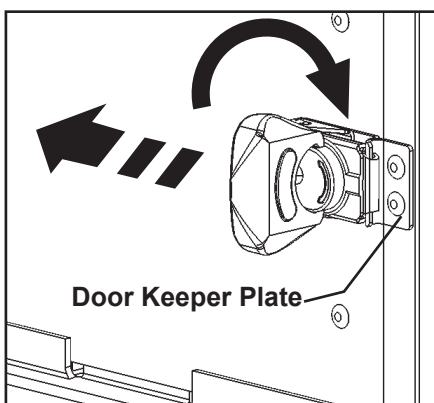

Testing Battery Charge

Automatic/Quick Test

1. Make sure Power Cord is unplugged.
2. Press Battery Charge Test Button on Main Control Panel, activating Battery Charge Level Indicator.
3. There are 3 charge zones on Level Indicator: DISCHARGED

(red), LOW (amber), and FULL (green). If charge level is FULL, the Battery is considered fully charged.

4. If Battery is not fully charged, charge for 12 – 48 hours depending on how low of a charge is indicated (very low charges require much longer charging times).
5. If Battery will not hold a charge, or if you suspect false results from Battery Charge Level Indicator and Battery may need to be replaced, a manual battery charge test is recommended.

Manual Test

1. Make sure Power Cord is unplugged.
2. Open Panel Access Door.
3. Apply positive lead of a handheld voltmeter to positive (red) battery terminal and negative voltmeter lead to negative (black) battery terminal.
4. Read voltage. Fully charged batteries show 11.8 – 13V. Batteries reading 11V or less after 12 - 48 hours of charging should be replaced.
5. Close the Panel Access Door.

⚠ WARNING:

- **ALWAYS** unplug Power Cord before testing Battery charge.
- Testing Battery charge with Power Cord plugged in will yield false results.

Battery Replacement

The ServerLIFT SL-500FX data center lift uses an onboard low-maintenance, VRLA (valve-regulated lead-acid), AGM (Absorbed glass mat) battery. It is sealed and spill-proof. Replacements are commonly available from suppliers of high performance marine or UPS style batteries, or directly through ServerLIFT Service & Support. Bring old Battery with you to supplier for comparison and safe disposal.

Construction	Nominal Voltage	Nominal Capacity	Terminal Type
ABS Plates AGM Separator	12 Volt	75 or 80 Ah	Internal
Length	Width	Height	Weight
10.20" 260 mm	6.61" 168 mm	8.43" 215 mm	52.53 lb 23.83 kg

ⓘ **Note:** *ONLY batteries with INTERNAL terminals will fit inside the ServerLIFT SL-500FX data center lift. Batteries with external terminals will not work and may cause fire or explosion.*

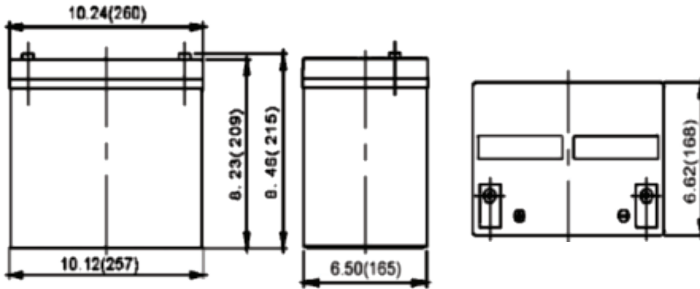

1. Open Panel Access Door.
2. A zip-tie installed to hold the Battery in place during shipping may be holding it in place. Cut or remove zip-tie. Zip-tie does not need to be replaced.
3. Pull red Battery Quick Disconnect out from its mate.
4. Remove Battery and Quick Disconnect wire assembly from shelf.

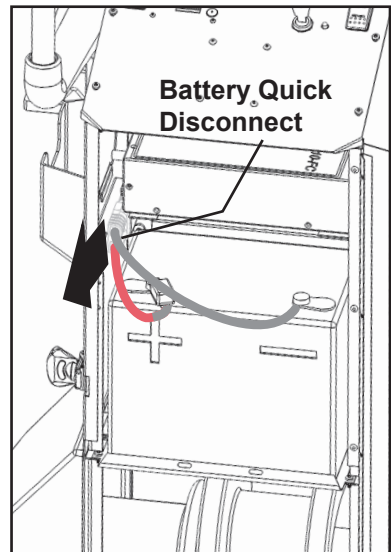

ⓘ **Note:** *Remove with care – Batteries weight 52 lb (23.5 kg)*

5. Loosen and remove terminal post from positive (red) battery terminal. Keep the post and all washers.
6. Repeat step 5 for negative (black) battery terminal.
7. Connect red end of Battery Quick Disconnect assembly to positive (red) terminal of new battery with post and washers. Ensure post is screwed on tightly.
8. Connect other end of Battery Quick Disconnect assembly to negative (black) terminal of new battery with post and washers. Ensure post is screwed on tightly.
9. Carefully put new Battery into place on shelf.
10. Insert red Battery Quick Disconnect receptacle to its mate, located on inside of panel enclosure.
11. Close Panel Access Door.
12. Verify ServerLIFT is receiving power from new Battery by turning it **ON** and cycling Platform up and down. Check that Battery Charge Level Indicator shows FULL when tested.

Stabilizer Brake Boot Replacement

1. Pull top corners of old boot out and down to remove from Stabilizer Brake Pad.
2. Press new boot on until it snaps in to place.

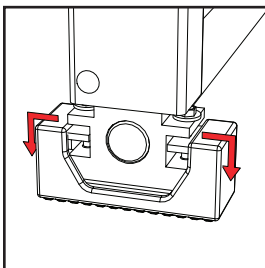

Removal

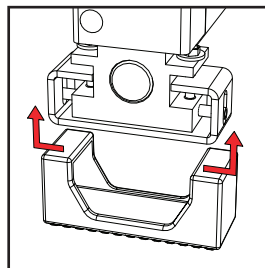

Installation

Pulley and Cable Inspection

Cable Inspection

1. Fully lower platform and inspect upper cable section.
2. Open Panel Access Door. Fully cycle Platform up and down while inspecting section of cable winding onto the winch motor.
3. When inspecting cable, look for:
 - **Wear or Corrosion**
 - **Broken wires or cut strands**
 - **Distortion, kinking, uneven strands, crushed parts, uneven cable diameter, or strands coming off**

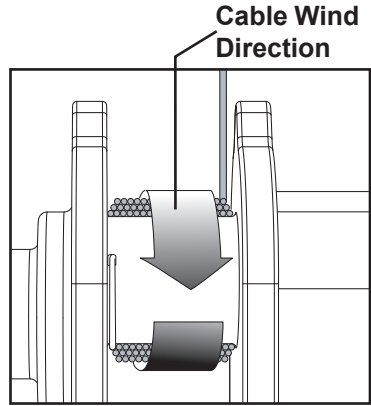

Discontinue use of ServerLIFT device if any cable damage is discovered upon inspection, and contact ServerLIFT Service & Support immediately. Do not attempt to repair or change cable.

Pulley Inspection

When inspecting pulleys, listen for squeaking, look for cracks, extreme wear, loose connections, and bent/damaged pulley guards.

➡ **Note: Bent or damaged pulley guards WILL interfere with cable operation. DO NOT attempt to operate with damaged pulleys.**

1. Remove Upper Panel Cover. Inspect Tension Switch Pulley.
2. From front of the machine, inspect Upper Pulley.
3. Inspect Lower Pulley from undercarriage of the ServerLIFT unit.

➡ **Note: Lower Pulley only be visible from undercarriage when Platform is completely lowered.**

If inspection reveals any pulley irregularities or damage, discontinue use of ServerLIFT device and contact ServerLIFT Service & Support immediately.

Features

Compact Design

- Slim 24" (61 cm) base easily navigates narrow aisles
- 4 oversized swivel casters for tight maneuvering and protection of raised floor tiles
- Swivel locks in front engage when straight tracking is required
- Fits through standard doorways
- Ideal for cold aisle containment rooms
- Overall heavy duty steel and aluminum construction
- Reusable packaging included for location transfers

Fully Contained

- Non-hydraulic heavy duty winch motor
- Powered by a rechargeable deep-cycle, AGM leak-proof/sealed (AGM), 12V VRLA battery
- Safe for data center floors

Heavy Duty Platform

- Minimal to no deflection or sagging even under full load
- Precise equipment alignment
- Included tie-down straps secure equipment during moves

Front-Loading Usability

- Supports equipment up to 11.5" (29.2 cm) into rack*
- Eliminates any obstruction of operator's view
- Easy alignment facing the rack

Easy-Glide Shelf

- 11.5" (29.2 cm) forward movement for supported loading
- Fits into standard 19" (48.25 cm) racks
- Micro-leveling SmartTILT™ shelf adjustment for precise alignment
- Seamless install from the platform into the rails

Smart Controls

- Precise height adjustment with proprietary microprocessor-controlled lifting system
- Dual side controls allow single operator to align equipment while facing the rack

*or 20" (50.8 cm) when used with the FE-3X attachment

Telescoping Mast

- SL-500FX Lift 500 lb (227 kg) to 8' or 2.45 m
- Quickly raise equipment to the top of travel in under 1 minute

TouchSTOP™ Sensor

- Proprietary sensing technology cuts power to machine on contact with ceiling, lights, cable trays, or other overhead obstructions
- Safety feature prevents equipment damage and injuries
- Enables safe use in contained and open environments without any modifications or adjustments

**TouchSTOP™
Sensor**

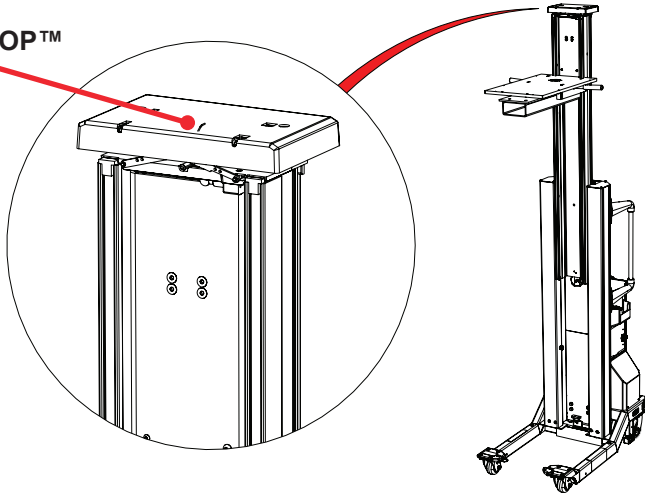

Locking Stabilizing Brake System

- Prevents unit from moving during installation
- Increases side-to-side stability

Safe Operation

- Eliminates manual lifting of equipment
- CE certified and FCC/IC classified
- Built-in solid state battery charger
- Cord management sleeve
- Secure key lock switch allows power lock-out of device when not in use or during loading to prevent accidents.
- Automatic safety stops in maximum upper and lower positions

Dimensions and Capacity, SL-500FX

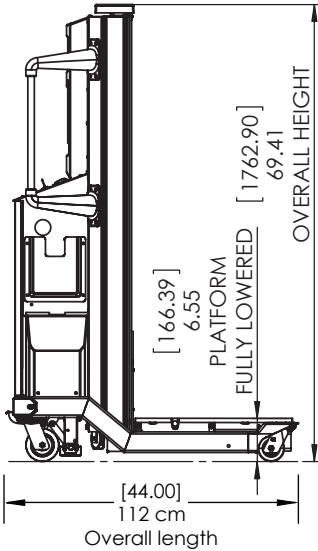

Working Dimensions	US	Metric
Platform Height, Extended	7.86'	2.40 m
Platform Height, Lowered	5.37"	13.6 cm
Shelf Movement per side	6.0"	15.2 cm
Movable Shelf Width	14.6"	36.8 cm
Platform Width	24"	61.0 cm
Platform Angle Adjustment	2°	2°
Rear Caster Wheel Diameter	5"	12.7 cm
Front Caster Wheel Diameter	4"	10.2 cm
Caster Wheel Width	2"	5.08 cm

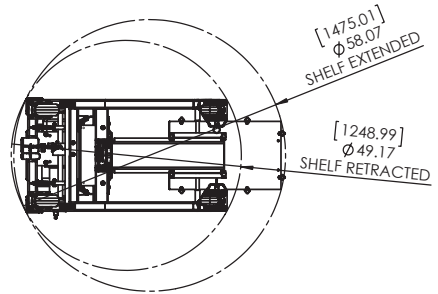
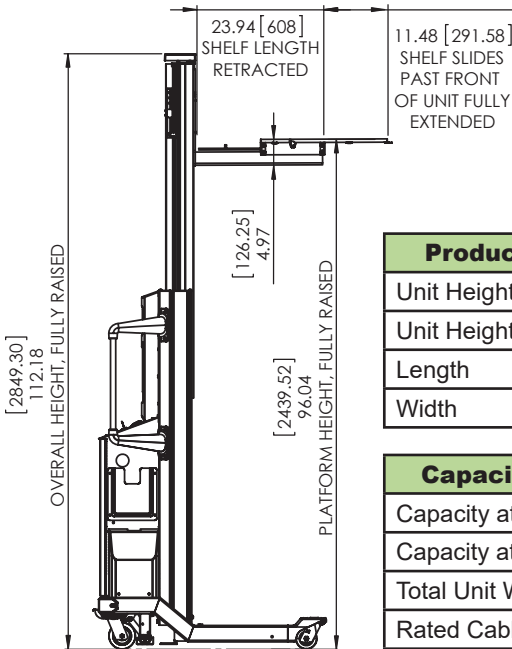

Product Dimensions	US	Metric
Unit Height (Lowered)	5' 9.4"	1.76 m
Unit Height (Raised)	9' 2.8"	2.81 m
Length	3' 8"	1.12 m
Width	2' 0.5"	0.62 m

Capacity and Weight	US	Metric
Capacity at Platform Center	500 lb	227 kg
Capacity at Platform Edge	300 lb	136 kg
Total Unit Weight	428 lb	194 kg
Rated Cable Failure Load	4000 lb	1814 kg

ServerLIFT Unit Does Not Move/Roll

Possible Cause	Solution
Brake is engaged.	Disengage Stabilizer Brake.
Obstruction with caster wheel.	Remove obstruction.
Caster wheel(s) damaged.	Replace damaged hardware.

Stabilizer Brake Does Not Work

Possible Cause	Solution
Stabilizer Brake Boot(s) missing.	Replace Stabilizer Brake Boot(s)
Operating on uneven floor.	Make sure unit is on even floor. Do not operate unit on uneven floor
Stabilizer Brake latch not engaging/locking.	Check undercarriage of unit to see if Stabilizer Brake latch is engaging. If it does not contact ServerLIFT Service & Support.

ServerLIFT Does Not Swivel/Turn

Possible Cause	Solution
Front Swivel Lock(s) engaged.	Disengage Swivel Lock(s).
Obstruction with caster wheel.	Remove obstruction.
One or more caster wheels damaged.	Replace damaged hardware.

Front Caster Wheels Do Not Lock

Possible Cause	Solution
Locking pin not engaging with caster groove.	Make sure there are no obstructions between pin and groove. Adjust caster wheel until engagement occurs. Detailed directions for this adjustment available from ServerLIFT Service & Support.
Caster groove or locking pin worn or damaged.	Replace worn or damaged hardware.

Easy-Glide Shelf Does Not Shift Forward or Back

Possible Cause	Solution
Handle is not unlocked from its position.	Press handle down. Attempt to shift Shelf forward and back.
Path of shelf is obstructed.	Locate and remove obstruction(s).
Rolling mechanism or locking mechanism is damaged.	Check under Platform for damaged part(s). Contact ServerLIFT Support for replacement parts.

Shelf Handle Won't Lock in Place

Possible Cause	Solution
Locking mechanism is damaged.	Check under Platform for damaged part(s). Contact ServerLIFT Support for replacement part.

Can't Adjust SmartTILT Platform Angle

Possible Cause	Solution
Platform reached it's maximum tilt angle in one direction.	Adjust platform angle in the other direction.
SmartTILT mechanism over-torqued in one direction.	Adjust platform angle in the other direction. If unable to adjust, contact ServerLIFT Service & Support.
Platform is in the lowest position.	Platform cannot be adjusted DOWN when it is in it's lowest position. Raise the Platform UP and re-attempt to adjust the Platform tilt angle.
Tilt mechanism is damaged.	Check under Platform for damaged part(s). Contact ServerLIFT Support for replacement parts.

Keylock Spins 360 Degrees

Possible Cause	Solution
Keylock D-groove damage or missing.	Replace Main Control Panel plate.
Keylock nut loose.	Tighten nut on underside of Main Control Panel and make sure Keylock wiring is secure.

Power On Indicated; No Functionality

Possible Cause	Solution
Low Battery charge.	Test and charge Battery. If Battery does not charge, follow troubleshooting above.
Wiring not connected to Main Circuit Board.	Open Panel Access Door. Check that all connections to Main Circuit Board are secure.
Main Circuit Board damaged.	Contact ServerLIFT Service & Support for replacement part. Replace Circuit Board.
Upper and/or Lower Limit Switches are activated.	Follow <i>Raises But Does Not Lower</i> and <i>Lowers But Does Not Raise</i> troubleshooting.

No Power Indicated; No Functionality

Possible Cause	Solution
Low Battery charge.	Test and charge Battery. If Battery does not charge, follow troubleshooting above.
Keylock Switch not turned to the ON position.	Turn Keylock Switch to ON position.
Battery is not connected.	Open Panel Access Door. Connect Battery Quick Disconnect to mating receptacle.
Wiring not connected to Main Circuit Board.	Open Panel Access Door. Check that all connections to Main Circuit Board are secure.
Main Circuit Board damaged.	Contact ServerLIFT Service & Support for replacement part. Replace Circuit Board.

Battery Does Not Charge

Possible Cause	Solution
Power not being supplied to the charger.	Check that Power Cord is plugged in to a live outlet within appropriate Voltage Input Range. If using an extension cord, check that it is working.
Battery Quick Disconnect loose or not connected.	Connect Battery Quick Disconnect.
Failed Battery.	Test Battery. Replace Battery if necessary.
Failed Charger.	If plugged in to a power source outside appropriate Voltage Input Range, Charger will fail. Check top of Charger from inside access panel. If plugged in and no lights are on, replace Charger.

Platform Raises But Does Not Lower

Possible Cause	Solution
Platform is obstructed.	Remove obstruction from below Platform.
Lower Limit Switch is stuck in the engaged/depressed position.	If Platform is not in its lowest position and there are no obstructions below it, remove Upper Panel Cover. Make sure all electrical connections to Lower Limit Switch are secure. Make sure Lower Limit Switch plunger is not stuck in depressed position. Make sure Tension Swing Arm is not engaging/depressing the switch plunger.
Damaged Circuit Board.	Contact ServerLIFT Service & Support for replacement part. Replace Circuit Board.

Platform Lowers But Does Not Raise

Possible Cause	Solution
TouchSTOP Sensor binding and stuck in engaged position.	Make sure no obstructions are binding TouchSTOP Sensor mechanism and mechanism is tightly secured. Manually unbind mechanism and ensure it travels down and springs back freely.
Upper Limit Switch is stuck in the engaged/depressed position.	To expose Upper Limit Switch, unscrew TouchSTOP Sensor mechanism retaining screws. These are accessed from two holes on top of TouchSTOP Sensor. Carefully pull mechanism slightly away from top of Vertical Mast. Locate Upper Limit Switch and make sure switch plunger is not stuck in depressed position.
Damaged Circuit Board.	Replace Circuit Board.

Up/Down Switch(es) Does Not Work

Possible Cause	Solution
No power to unit.	Follow <i>No Power Indicated</i> troubleshooting above.
Wiring to Switch(es) loose or not connected.	Open Panel Access Door. Check that all connections to Switch(es) are secure.
Switch(es) have failed.	Contact ServerLIFT Service & Support for replacement part(s). Replace Switch(es).

SERVERLIFT DATA CENTER LIFT LIMITED WARRANTY

LIMITED WARRANTY COVERAGE

The limited warranty covers defects in materials and workmanship of the ServerLIFT SL-500FX® data center lift (collectively “Equipment”). The warranty is not transferable and must be registered at <https://serverlift.com/register>. The warranty applies only to the original end-user owner of the Equipment unless prior written notice is received by and approval given by ServerLIFT.

For the Warranty Periods listed below, ServerLIFT Corporation (henceforth “ServerLIFT”) warrants that the Equipment:

1. Will be free from defects in materials and workmanship.
2. Will perform substantially in accordance with ServerLIFT’s published specifications.

ServerLIFT will ship any parts that are in-warranty at no charge in accordance with the Limited Warranty Return & Repair Policy listed below. ServerLIFT will provide repair or replacement instructions as needed.

LIMITED WARRANTY PERIODS

The Warranty Period is one year from the day of delivery except for the following components:

<u>Component/Equipment</u>	<u>Warranty Period</u>
Structural	10 years
Battery	1 year ¹

¹ Cost of replacement battery only. Does not include labor, shipping, or disposal of old battery.

LIMITED WARRANTY EXCLUSIONS

The warranty is void if:

- The applicable Warranty Period has expired;
- The Equipment has missing or altered serial numbers; or
- The Equipment has been repaired or modified by an agent not authorized by ServerLIFT.

The warranty specifically excludes damage to the Equipment, including but not limited to:

- Damage incurred during shipment (other than shipping with a ServerLIFT contracted carrier);
- Damage caused by impact with other objects, drops or falls, including external case cracks, dented or punctured case, broken latches, torn covers, broken doors, or physical breakaway of internal components;
- Damage caused by intrusion of foreign matter into the Equipment;
- Damage to internal components caused by power surge;
- Damage to electrical connectors including corrosion, broken and/or bent pins;
- Damage to Equipment caused by environmental corrosion;
- Damage caused by improper maintenance;
- Damage caused by use of appurtenances not supplied by ServerLIFT or failures which result from alterations, modifications or foreign objects;
- Damage caused by the use of the Equipment for purposes other than for which it was designed
- Damage caused by other abuse, misuse, neglect, accident, negligence, mishandling or misapplication; and
- Damage attributable to acts of G-d.

LIMITED WARRANTY RETURN & REPAIR POLICY

For warranty assistance call ServerLIFT Corporation at 1-602-254-1557 between 9:00 a.m. and 5:00 p.m. Mountain Standard Time, Monday through Friday (excluding observed holidays), email support@serverlift.com or visit <http://serverlift.com/support/>.

As part of the terms of this warranty, you may be required, as needed, to assist ServerLIFT's remote support staff with gathering information needed to make a warranty claim and/or repair. This includes, but is not limited to troubleshooting, testing, and providing pictures and/or video of the issue(s). Failure or refusal to provide ServerLIFT with the requested information may result in the invalidation of the claim as covered by this warranty.

Equipment that fails to comply with this warranty shall, at ServerLIFT's sole discretion, be repaired or exchanged for an equivalent replacement. You are responsible for returning the non-conforming Equipment, properly packaged, to ServerLIFT during the Warranty Period. ServerLIFT will pay return shipping costs of Equipment serviced under the Limited Warranty.

To obtain warranty service or to return Equipment, written notification must be made to ServerLIFT in advance via email (support@serverlift.com) or fax (1-602-412-4479) that must include the following information:

- Equipment serial number;
- Date of original Equipment receipt;
- Original ServerLIFT invoice and/or invoice number (proof of purchase);
- Contact information of the end-user and location of Equipment; and
- Description of the problem and/or desired service action.

In the event of a return or repair that is determined to occur at ServerLIFT's facilities, you will be issued a Warranty Repair Authorization (WRA) or case number and shipping instructions. Otherwise, ServerLIFT will arrange onsite service based on a mutually convenient schedule.

Equipment returned with a void warranty and/or without prior notification to and approval from ServerLIFT may be repaired and/or shipped back to the end-user at their expense.

If it is determined that the problem is not covered under warranty, you will be contacted with service alternatives available on a time and materials basis. You will also be responsible for all applicable shipping costs.

WARRANTY LIMITATIONS

IN NO EVENT SHALL SERVERLIFT BE LIABLE, WHETHER IN CONTRACT, NEGLIGENCE, TORT, OR ON ANY OTHER BASIS, FOR COVER OR FOR INCIDENTAL, CONSEQUENTIAL OR EXEMPLARY DAMAGES ARISING OUT OF OR IN CONNECTION WITH THE SALE, SERVICES, MAINTENANCE, USE, PERFORMANCE, FAILURE, OR INTERRUPTION IN THE OPERATION OF EQUIPMENT, SERVICES, HARDWARE OR SOFTWARE, EVEN IF SERVERLIFT IS ADVISED OF THE POSSIBILITY OF SUCH DAMAGES. THE WARRANTY IS IN LIEU OF ALL OTHER WARRANTIES, WHETHER EXPRESS, IMPLIED OR STATUTORY. SOME STATES DO NOT ALLOW LIMITATIONS ON IMPLIED WARRANTIES SO THIS LIMITATION MAY NOT APPLY TO YOU.

This warranty and performance hereunder shall be governed by and construed in accordance with the laws of the State of Arizona without reference to its choice of law principles.

WARRANTY EXTENSIONS AND SERVICE CONTRACTS

Extended warranty periods and service contracts are available to suit your specific needs. To learn more about these optional service programs contact ServerLIFT Service & Support via e-mail (support@serverlift.com) anytime or by phone (1-602-254-1557) 9:00 AM to 5:00 PM Mountain Standard time, Monday through Friday (excluding observed holidays).



Declaration of Conformity

Manufacturer: ServerLIFT Corporation
17453 N 25th Ave
Phoenix, AZ 85023 USA
602-254-1557
www.serverlift.com

Model numbers: SL-500X[®], SL-500XI[™], SL-500FX[™], SL-500FXI[™]

Max. Load Capacity: 227 kg (500 lbs)

Type of equipment: Server and IT equipment lifting machine

We declare that the product identified above meets the requirements of the following EU directives and standards for the purpose of CE compliance:

Directives/Standards:

Immunity Standards

IEC/EN 61000-6-1: 2016

Generic Standards - Immunity for Industrial Environments

IEC/EN 61000-4-2:

Electrostatic Discharge (ESC)

IEC/EN 61000-4-3:

Radiated, radio frequency, Electromagnetic Field Immunity Test

IEC/EN 61000-4-4:

Electrical Fast Transient/Burst Immunity Test (EFT)

IEC/EN 61000-4-5

Surge Immunity Test (Mains)

IEC/EN 61000-4-6

Immunity to Conducted Disturbances, Induced by Radio Frequency Fields

IEC/EN 61000-4-8

Power Frequency Magnetic Field Immunity Test

IEC/EN 61000-4-11

Voltage Dips, Short Interruptions and Voltage Variations Immunity Test



Declaration of Conformity

Manufacturer: ServerLIFT Corporation
17453 N 25th Ave
Phoenix, AZ 85023 USA
602-254-1557
www.serverlift.com

Model numbers: SL-500X[®], SL-500XI[™], SL-500FX[™], SL-500FXI[™]

Max. Load Capacity: 227 kg (500 lbs)

Type of equipment: Server and IT equipment lifting machine

We declare that the product identified above meets the requirements of the following EU directives and standards for the purpose of CE compliance:

Emissions Standards

IEC/EN 61000-6-4: 2018

Generic Standard - Emission standard for Industrial Environments

CISPR 32 / CISPR 11 Radiated Emissions

CISPR 32 / CISPR 11 Conducted Emissions

Product Safety Directives

Machinery Directive 2006/42/EC

Low Voltage Directive (LVD) 2006/95/EC, IEC EN 60950

Name: Mr. Raymond Zuckerman

Title: CEO

Date: 09/05/2018



Declaration of Conformity

Client: ServerLIFT Corporation

Model numbers: SL-500FX™, SL-500FXI™

Type of equipment: Lifting device for IT equipment for use in data centers

Manufacturer: ServerLIFT Corporation
17453 N 25th Ave, Phoenix, AZ 85023 USA
602-254-1557

Report Date: March 1 and 4, 2019

Test Performed By: Compatible Electronic Inc.
20621 Pascal Way
Lake Forest, CA 92630
Ph: 949-587-0400

Report Date: FCC Part 15B, Class A

FCC 15.19(a) (3):

This device complies with part 15 of the FCC Rules.
Operation is subject to the following two conditions:

1. This device may not cause harmful interference, and
2. This device must accept any interference received, including interference that may cause undesired operation.

Name: Mr. Raymond Zuckerman

Title: CEO

Date: 01/17/2020



serverLIFT

www.serverlift.com

© ServerLIFT Corporation. All Rights Reserved.

SL, ServerLIFT, SL-1000X, SL-500X, SL-500FX, SL-350X, and TouchSTOP
are trademarks of ServerLIFT Corporation