

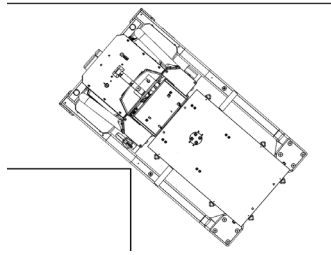

SL-1000X™ SUPER DUTY FINE ADJUST Electric Data Center Lift

Dimensions: [cm] in

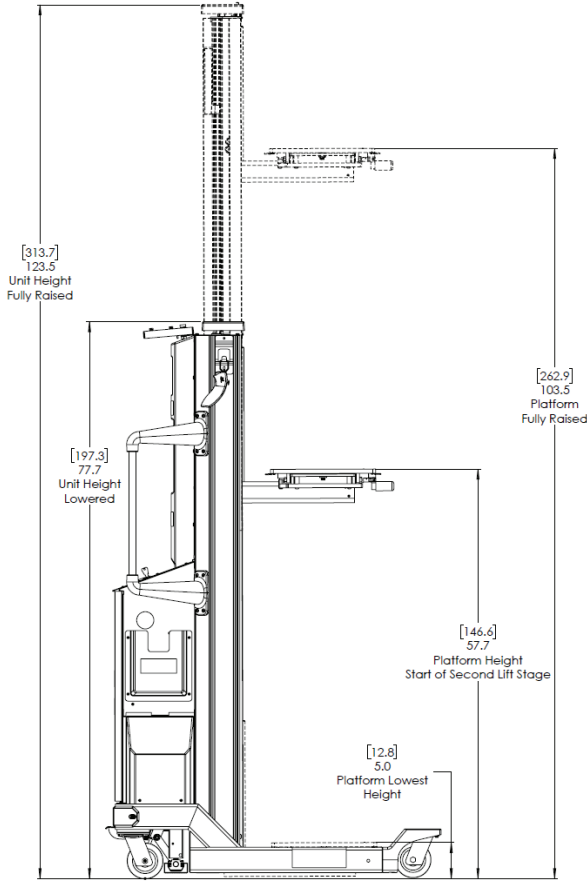
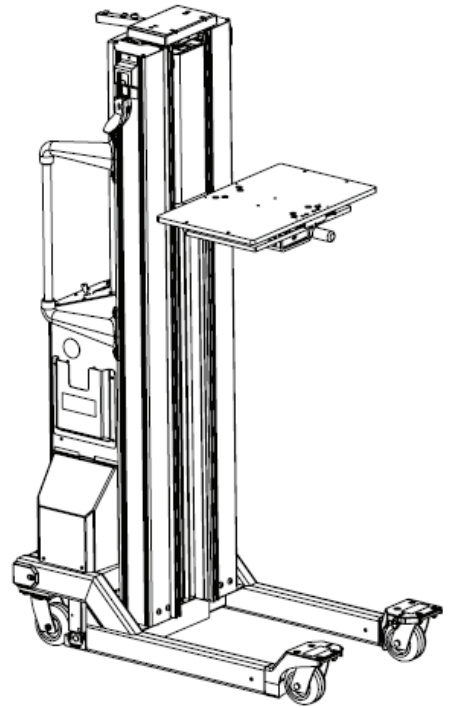

The lift can smoothly transition from a 32-inch aisle to a 40-inch aisle.

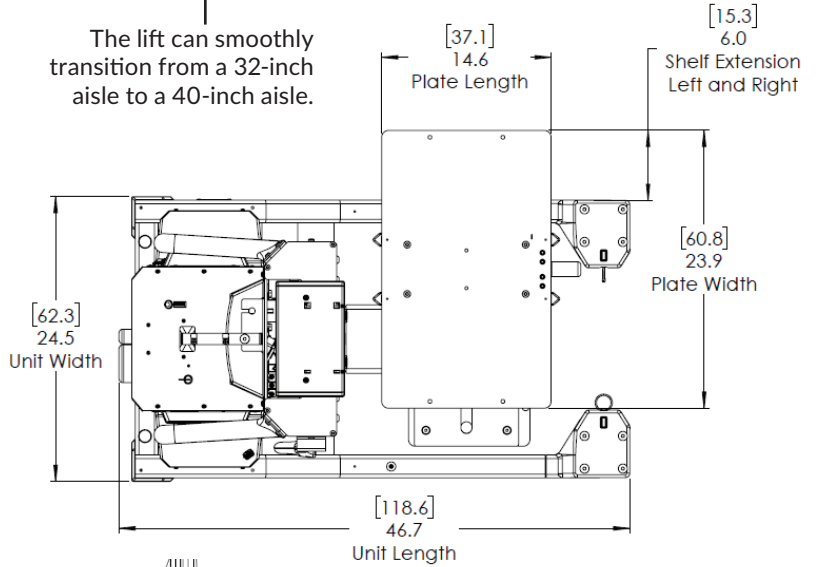

Push joystick to move platform

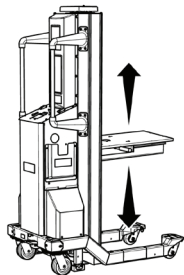
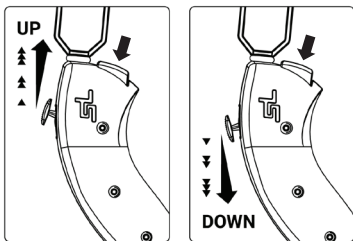

- ✓ The pendant can hang on either side of the lift.
- ✓ The pendant has progressive speed control for precise equipment positioning.
- ✓ The safety button must be held throughout the

Hang pendant on left or right side

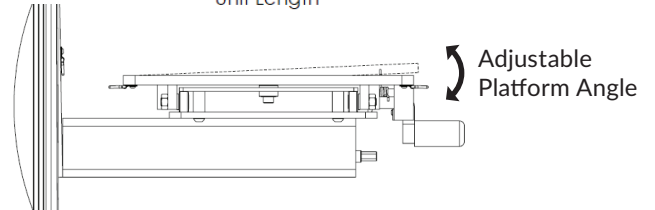
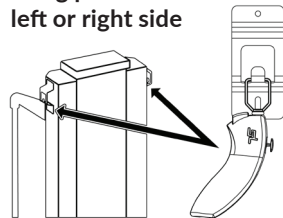

Front Caster Swivel Lock Operation



Capacity

DESCRIPTION	US (lb)	METRIC (kg)
Platform center (Platform retracted)	1000	400
Platform edge (Platform extended)	400	182

Weight

DESCRIPTION	US (lb)	METRIC (kg)
Total unit weight	530	241
Shipping weight	675	306